

THIS DRAWING IS UNPUBLISHED. RELEASED FOR PUBLICATION ,19
 © COPYRIGHT 19 BY AMP INCORPORATED. ALL INTERNATIONAL RIGHTS RESERVED.

LOC	DIST	P	F	ZONE	LTR	DESCRIPTION	DATE	APPD
AF	50				E	REV PER ECR 06-010492	02OCT06	JR/GP

IDENTIFICATION NUMBER FOR MAGNET WIRE RANGE

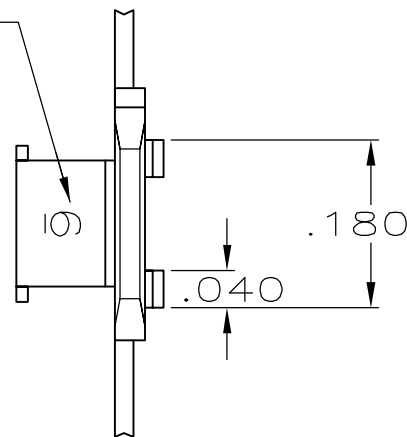

- 1 MAG-MATE CAVITY SPECIFICATION.
- 2 CONTINUOUS STRIP ON REELS WITH TERMINALS LOCATED ON $.330 \pm .003$ CENTERS.
- 3 SLOT TERMINATES EITHER SINGLE OR DOUBLE MAGNET WIRES OF THE SAME TYPE AND SIZE, COPPER RANGE IS #30-#27 AWG.

FITS .250 SERIES FASTON RECEPTACLE

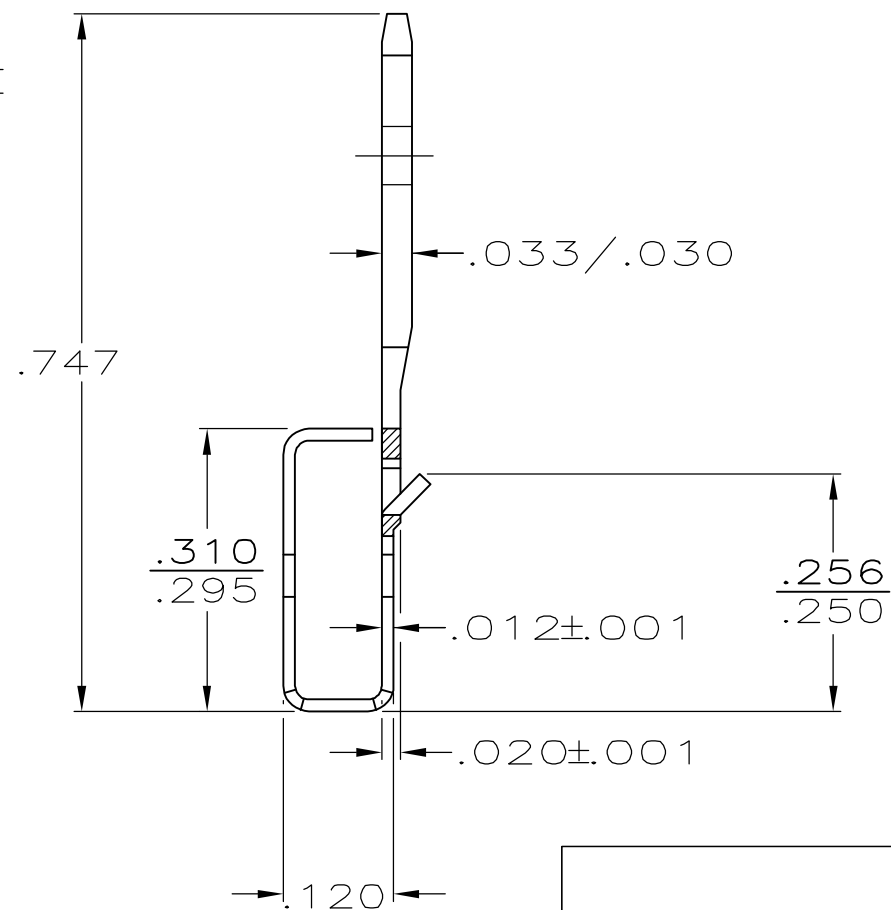
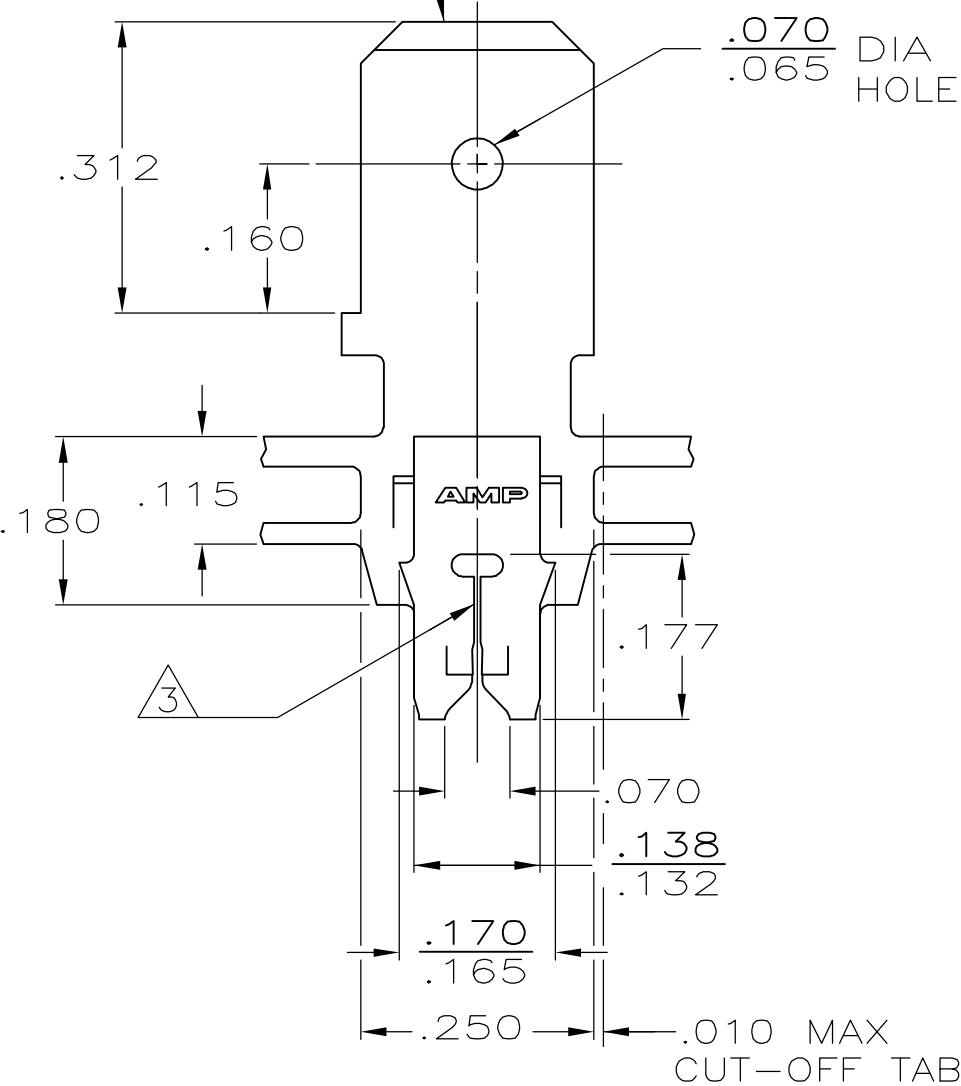

082 PRE-MILLED BRASS	63499-2
4M PRE-MILLED BRASS	63499-1
FINISH	PART NO

DO NOT SCALE PRINT. UNLESS SPECIFIED DIMENSIONS IN INCHES TOLERANCES ON: 2 PLC DEC ± - 3 PLC DEC ± .010 ANGLES ± -	DR M.S. FEHER 6/30/88	AMP INCORPORATED Harrisburg, Pa. 17105	
	CHK JR RUTH 7/7/88		
MATERIAL SEE TABLE	APPD N.E. NEFF 7/8/88		NAME TAB, 250 FASTON,™ MAG-MATE™
FINISH .000080 MIN TIN	APPD C G ATHERTON 7/8/88		SIZE B FSCM NO 00779 DRAWING NO 63499
	PRODUCT SPEC 108-2012	SCALE 5:1 SHEET 1 OF 1	
	APPLICATION SPEC 114-2094 1		
	WEIGHT -		